

General Description

The TMR6206D is a type of 6 channels magnetic pattern recognition sensor built-in the signal conditioner and SPI interface. The TMR6206D consists of TMR magneto-resistance sensor, high-quality magnet, high-strength plastic base and durable non-magnetic stainless steel cover; The TMR6206D series are used for detecting the paper bills, bank notes and security documents with magnetic anti-counterfeiting consists. The appearance is shown in Figure. 1.

Features and Benefits

- SPI interface
- ADC resolution 12bit
- High sensitivity and excellent gap performances
- Output voltage is independent of scanning speed
- Durable metal case, suitable for long time and heavy load situations
- 10mm x 6ch detection width, no non-detection area
- Factory calibration before shipment

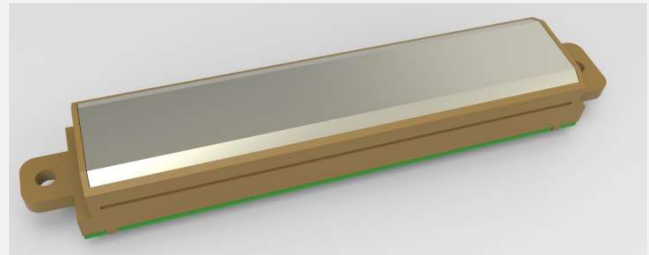

TMR6206D Magnetic Pattern Recognition Sensor Appearance

Applications

- ATM
- Bill counter and validator
- Bill sorter
- Magnetic detection of the paper bills

Connector and Pin Configuration

Connector P/N:

FH12A-22S-0.5SH (HRS)

TMR6206D Pin Configuration:

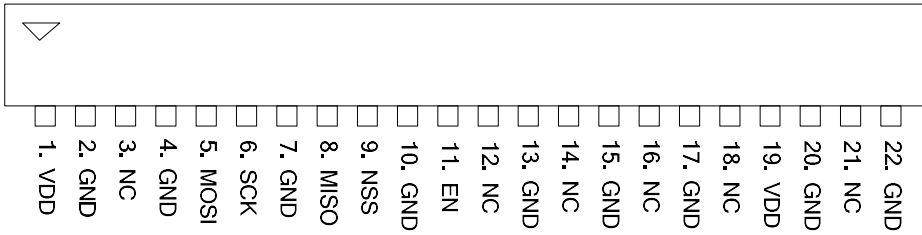

Pin No.	Symbol	Description
1, 19	VDD	Power supply 5V
2, 4, 7, 10, 13, 15,17, 20, 22	GND	Ground
5	MOSI	SPI master output slave input (slave mode)
6	SCK	SPI clock input
8	MISO	SPI master input slave output (slave mode)
9	NSS	SPI slave selection
11	EN	Power enable, high-level to enable, low-level to shutdown
3, 12, 14, 16, 18, 21	NC	No connected

Mechanical Drawings

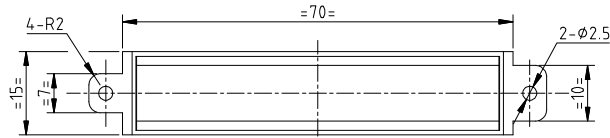
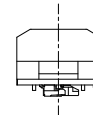
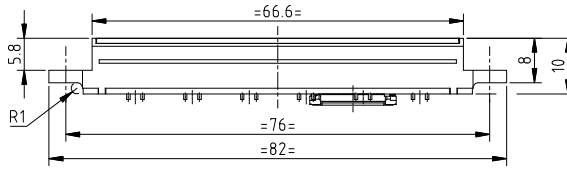
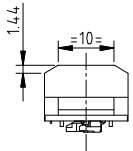
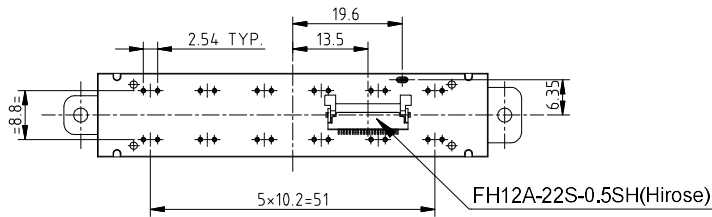

Case: plastic
 Cover: stainless steel thickness 0.2mm
 unit:mm

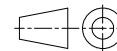

TMR6206D Mechanical Drawing

Absolute Maximum Ratings

Parameter	Symbol	Rating	Unit
Maximum supply voltage	V_{DD}	5.5	V
Maximum input voltage	EN	-0.3 ~ 5.5	V
	SCK, MISO, MOSI, NSS	-0.3 ~ 3.6	
Operating temperature range	T_A	-20 ~ 65	°C
Storage temperature range	T_{stg}	-30 ~ 85	°C
Operating humidity	HMD	10~90(no dew)	%RH

Electrical Parameters ($V_{DD}=5V, T_A=25^\circ C$)

Parameter	Symbol	Test Condition	Min.	Typ.	Max.	Unit
Supply voltage	V_{DD}		4.75	5	5.25	V
Power-on delay time	t_{ON}	EN from low to high			5	ms
Power-off delay time	t_{OFF}	EN from high to low			0.5	ms
High-level input voltage	V_{IH}	SCK, MOSI, NSS, EN	2.7		3.3	V
Low-level input voltage	V_{IL}		0		0.4	V
High-level output voltage	V_{OH}	MISO	2.4		3.3	V
Low-level output voltage	V_{OL}		0		0.4	V
Current consumption	I_{CC}	$V_{DD} = 5V$		100	200	mA
ADC reference voltage	V_{REF}	$V_{DD} = 5V$		3.3		V
ADC resolution	RSL			12		Bits
Noise ⁽¹⁾	Noise	1k sampling points			310	digit
No signal base level	Base		1900	2048	2200	digit
Cycle Sampling rate	f_s	CH1 to CH6 as 1 cycle			10	ksps
Sampling hold time	t_{ACQ}	When received "START" command	70			us

To be continued.

Continue.

Parameter	Symbol	Test Condition	Min.	Typ.	Max.	Unit
Magnetic Pattern Recognition Sensor Parameters						
Sensitivity ⁽²⁾	S			1600		digit
Surface magnetic field	B	On sensing surface (S pole)		800		Gs
Number of channels	C			6		
Detection width	W			10		mm
Resolution	T			0.475		mm

Notes:

- (1) Cycle sampling rate is 10ksps, measure the peak-to-peak voltage.
- (2) According to the MultiDimension sensitivity measurement.

Time and Function Definition

SPI Timing Definition:

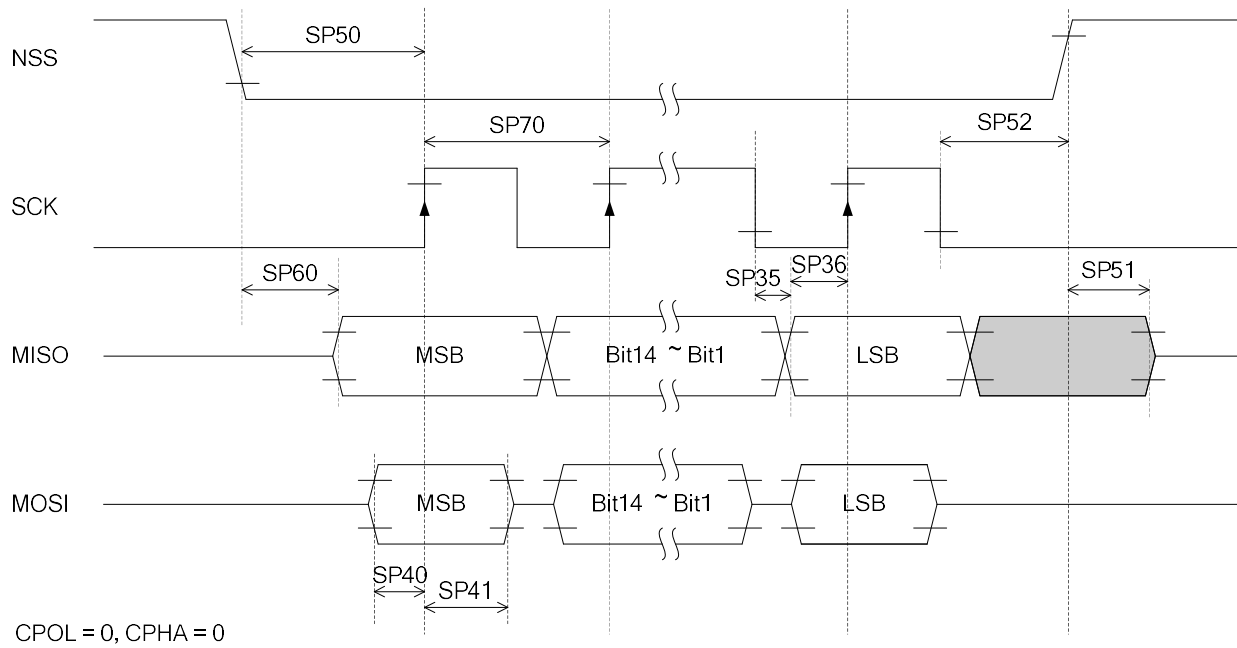

Symbol	Description	Min.	Typ.	Max.	Unit
SP35	MISO data output valid after SCK edge		6	20	ns
SP36	MISO data output setup to first SCK edge	40			ns
SP40	Setup time of MOSI data input to SCK edge	30			ns
SP41	Hold time of MOSI data input to SCK edge	30			ns
SP50	Time of NSS edge to SCK edge	120			ns
SP51	Time of NSS edge to SCK edge	10		50	ns
SP52	NSS edge after SCK edge	70			ns
SP60	MISO data output valid after NSS edge			50	ns
SP70	Maximum SCK input frequency			12	MHz

Data Format of One Sampling Cycle

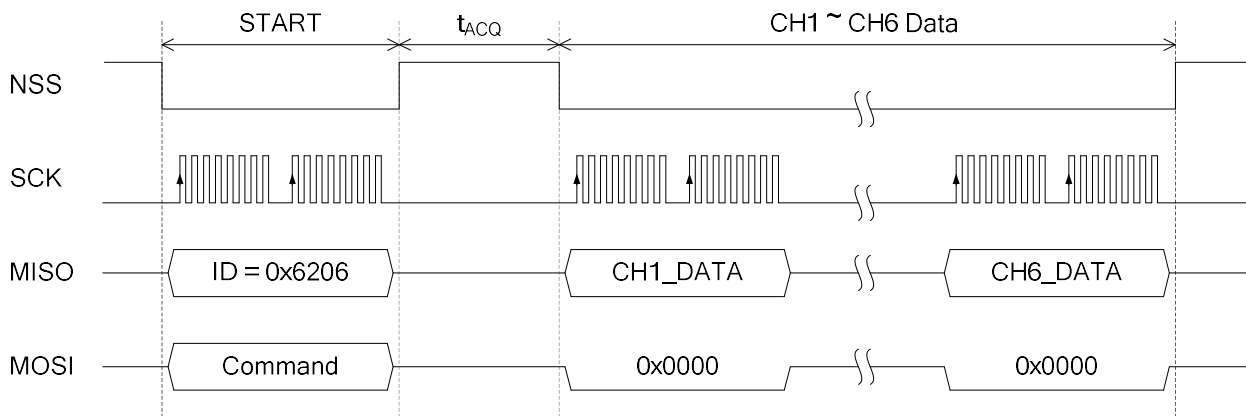

The master sends START command to the slave sensor, when the slave sensor has received the START command, the slave will start the sampling function, the master should be waiting for the sampling hold time (t_{ACQ}) during the slave sensor sampling function, then the slave sensor will send back the each channel's data from CH1 to CH6.

Command Format

Bit	15	14	13	12	11	10	9	8	7	6	5	4	3	2	1	0
Command	1	1	0	1	0	1	0	1	0	0	0	0	0	1	1	0

bit 15 ~ 0 Fixed value 0xD506, indicated the sampling start command

ID Format

Bit	15	14	13	12	11	10	9	8	7	6	5	4	3	2	1	0
ID	0	1	1	0	0	0	1	0	0	0	0	0	0	1	1	0

bit 15 ~ 0 Fixed value 0x6206, indicated the TMR6206 serials products

CHn_DATA Format

Bit	15	14	13	12	11	10	9	8	7	6	5	4	3	2	1	0
CHn_DATA	0	0	0	0	Channel-n 12bits ADC data											

bit 15 ~ 12 High-order 4 bits are set to 0

bit 11 ~ 0 The slave sensor sends back the 12 bits ADC data of the dedicated channel n

Caution for Use

- The sensor contains a permanent magnet, it will cause the recordable magnetic media damaged, such as cassette tapes, floppy disks, credit cards, hard drives, keep it away from such types of magnetic media.
- To avoid the ferromagnetic particles being collected from a dirty environment.
- Magnets tend to snap to each other or the magnetic metals, be careful when handling the sensor not to apply mechanical shock, otherwise the sensors might be abnormal or break.
- Do not place the sensor near the person who has an electronic medical device. It is very dangerous and may cause malfunction of an electronic medical device.
- Magnetic devices may be subject to special transport regulations.
- To avoid the abrasion of the sensor's metal case or stuck the banknote, about 0.1mm gap between the sensor and the opposite side such as rollers is recommended to reduce the pressure of the sensor's metal case.
- To avoid excessive force on terminals, please mount the sensor's base firmly on the PCB and solder all the terminals.
- Hand soldering should be applied, the soldering temperature should be $350 \pm 10^{\circ}\text{C}$ less than 3 seconds or $260 \pm 5^{\circ}\text{C}$ less than 10 seconds



American Electronic Components Inc.

1101 Lafayette Street, Elkhart, Indiana 46516, United States of America.

Web: www.aecensors.com Email: sales@aecensors.com

Toll: 888 847 6552, Tel: +1 574 293 8013

The information provided herein by MultiDimension Technology Co., Ltd. (hereinafter MultiDimension) is believed to be accurate and reliable. Publication neither conveys nor implies any license under patent or other industrial or intellectual property rights. MultiDimension reserves the right to make changes to product specifications for the purpose of improving product quality, reliability, and functionality. MultiDimension does not assume any liability arising out of the application and use of its products. MultiDimension's customers using or selling this product for use in appliances, devices, or systems where malfunction can reasonably be expected to result in personal injury do so at their own risk and agree to fully indemnify MultiDimension for any damages resulting from such applications.